

## An Explanatory Framework for Chemistry Education: The Two-World Model

### Kimya Eđitimi İin Aıklayıcı Bir Yapı: İki Dnya Modeli

Blent PEKDAĐ\*

Balıkesir University

Jean-Franois LE MARÉCHAL\*\*

Ecole Normale Supérieure de Lyon

#### *Abstract*

This study offers chemistry teachers, educators and researchers a useful explanatory framework – “the two-world model” – to assist them in establishing and understanding students’ thoughts about concepts or phenomena in chemistry. The chemical reaction concept has been selected as an example in introducing the two-world model within the scope of this work. Differing from previous studies in which this concept has been treated in the context of chemistry education, the present study uses the two-world model to set forth how 94 students between the ages of 15-16, define the chemical reaction concept. The students’ meaning constructions about chemical reactions were examined under two different conditions. One of the conditions involved pairs of students watching a short video demonstrating an esterification reaction and then answering six questions that provoked a discussion between them. The other condition entailed students working in the laboratory on the same experiment while a set of questions stimulated the students to reflect upon the experiment. Both students’ observations were compared in order to understand the arguments they developed as they tried to convince each other that their observations could be (or could not be) interpreted as chemical reactions. It was found that after the video, the students’ arguments adhered to perceptible levels of knowledge whereas during the laboratory work, students had developed reconstructed arguments in connection with the perceptible world. This study offers recommendations based on the results obtained that will be useful to chemistry teachers, educators and researchers.

*Keywords:* Chemistry education, two-world model, chemical reaction, video, laboratory work.

#### *Öz*

Bu alıřma, kimyasal kavramlar veya fenomenler hakkında öđrencilerin ne dřündüklerini tespit etmede ve anlamada kimya öđretmenlerine, eđitimcilerine ve arařtırmacılarına faydalı olacak aıklayıcı bir yapıyı – “iki dnya modelini” – tanıtmaktadır. Bu alıřma kapsamında, iki dnya modelinin tanıtımı iin kimyasal reaksiyon kavramı örnek olarak seilmiřtir. Bu kavramı konu alan önceki alıřmalardan farklı olarak, 15-16 yařındaki 94 öđrencinin kimyasal reaksiyon kavramını nasıl tanımladıkları iki dnya modeli kullanılarak ortaya konmuřtur. Kimyasal reaksiyon kavramı hakkında öđrencilerin anlam oluřturmaları iki farklı durumda incelenmiřtir. Birinci durum ierisinde, öđrenci iftleri esterleřme reaksiyonunu konu alan kısa bir video izlediler ve öđrenci tartıřmalarına imkân veren 6 soruya cevap verdiler. Diđer durum ierisinde,

\* Assist. Prof. Dr. Blent PEKDAĐ, Balıkesir University, Necatibey Education Faculty, Chemistry Education, Balıkesir 10100 TURKEY, pekdag@balikesir.edu.tr

\*\* Prof. Dr. Jean-Franois LE MARÉCHAL, Ecole Normale Supérieure de Lyon, Chemistry Education, 69364 Lyon Cedex 07 FRANCE, lemarch@ens-lyon.fr

öğrenciler aynı esterleşme reaksiyonunu konu alan bir laboratuvar çalışması gerçekleştirdiler ve bir dizi soruya cevap verdiler. Her iki durum içerisinde, kimyasal reaksiyon kavramını ortaya koyan öğrenci argümanları karşılaştırıldı. Video izleyen öğrencilerin argümanları algılama dünyası ile ilişkili iken, laboratuvar çalışması yapan öğrencilerin argümanları ise algılama ve yeniden yapılandırılmış dünya arasındaki ilişkiler üzerine kuruluydu. Elde edilen sonuçlar ışığında bu araştırma, kimya öğretmenlerine, eğitimcilerine ve araştırmacılara faydalı olacak öneriler içermektedir.

*Anahtar Sözcükler:* Kimya eğitimi, iki dünya modeli, kimyasal reaksiyon, video, laboratuvar çalışması.

## Introduction

Many studies have been conducted to reveal students' understanding of chemical concepts and phenomena (Agung and Schwartz, 2007; Gabel, Samuel and Hunn, 1987; Nakhleh, 1992; Novick and Nussbaum, 1981; Sanger and Greenbowe, 1997; Schmidt and Volke, 2003; Tan and Taber, 2009). These studies indicate that what students understand is not consistent with the consensus of the scientific community. Many students have trouble comprehending chemical concepts and some students display incomplete understanding. Many students from middle school to university level have difficulty with concepts in chemistry (Cakmakci, Leach and Donnelly, 2006; Cokelez, Dumon and Taber, 2008; Gopal, Kleinsmidt, Case and Musonge, 2004; Stefani and Tsaparlis, 2009).

The concept of chemical reaction is a central concept in studying chemical change from both a scientific and a teaching point of view. Teaching and learning such a concept is a very complex human endeavor because it may be difficult to teach due to the large number of facts and concepts that have to be considered simultaneously (Hesse and Anderson, 1992). The learning activity related to the concept of chemical reaction has been broadly documented since the 1980s (Andersson, 1986; Barker and Millar, 1999; Ben-Zvi, Eylon and Silberstein, 1987; Boo and Watson, 2001; Cavallo, McNeely and Marek, 2003; De Vos and Verdonk, 1985; Mulford and Robinson, 2002; Stains and Talanquer, 2008; Stavridou and Solomonidou, 1998; Van Driel, De Vos, Verloop and Dekkers, 1998).

Research by Ben-Zvi, Eylon and Silberstein (1987) showed that some students (aged 15 years) appeared to view chemical reaction as additive rather than interactive. They visualized chemical reaction as a process where reactants were added to form products, rather than as a process involving bonds breaking and forming. Boo and Watson (2001) explored the conceptions of 48 students, ages 16-18, about chemical reactions and how their conceptions change in response to teaching. The results have shown that students made some progress in their understanding of the concept of chemical reaction, but some fundamental misconceptions remained. Most students tended to use causal reasoning: that either one or more of the chemicals involved caused the reaction to happen or that heat did. A major difficulty for students lies in understanding why chemical reactions occur. Students often identify heat, flames, or fire as the causal agent of change (Boo and Watson, 2001; Krnel, Watson and Glažar, 1998).

Previous studies indicate that students have a lack of understanding of chemical reaction. Students (aged 12-18) think that a chemical reaction results in a new product, but they comprehend the new product formation on the basis of some common-sense criteria, i.e. the new product is simply something different from the initial one (Stavridou and Solomonidou, 1998). Some pupils (aged 11-13) claim that the reaction between substances means the mixing of substances and that only some properties (e.g. color) change, while the substance remains the same (De Vos and Verdonk, 1985). Pupils reorganize their conceptual domain and construct the chemical reaction concept in quite personal ways. In many cases, students explain chemical phenomena in terms of physical changes, most frequently changes of state or form. The attention is focused on visible properties only before the change and after. A chemical reaction is associated with changes at a macroscopic level that can be observed directly (e.g. color change) (Hesse and Anderson, 1992;

Stavridou and Solomonidou, 1998; Van Driel, De Vos, Verloop and Dekkers, 1998). It is impossible for many students to distinguish physical and chemical change (Sanmarti, Izquierdo and Watson, 1995). Students (aged 8-17) express their conception that only physical changes are reversible. Chemical changes to them are always seen as irreversible (Stavridou and Solomonidou, 1989). This difficulty in distinguishing chemical and physical change is carried through to the microscopic level (Boo and Watson, 2001).

In familiar or unfamiliar situations, teaching chemical reactions cannot be carried out with students without experimental realization. French institutions require experiments to be realized by teachers and/or by students. When the teacher carries out the chemical reaction by him/herself, it lasts for a few minutes but when the students are conducting reactions during a laboratory work session, it takes between one to two hours. The knowledge about how students interpret these two ways of realizing an experiment is one of the topics investigated in the current study. Moreover, we wanted to find out what makes students think such observations would correspond to a chemical reaction. One of our hypotheses was that although during the experiment, students observe a large number of facts, usually only a few of these correspond to the chemical reaction. Which facts are more likely to be considered by students as indicators of the possible occurrence of a chemical reaction is a central question of the present work. In the framework of learning about chemical reactions, we were also interested in the arguments students would use in their reasoning to convince themselves or their schoolmates that they were in the presence of a chemical change.

We have tried to answer this question through a quite different approach than those that have been described since we involved students who knew almost nothing about the atomic structure of matter or the chemical symbolism in an organic chemical reaction between an alcohol and an acid (esterification). During such a reaction, there is no spectacular event such as flames or any other elaborate chemical reaction that would distract students' attention from the chemical change. Neither is the reaction an immediate one such as a precipitation reaction, which is often aimed at stimulating students to formulate and write down a chemical equation. No gas was used as a reagent or as a product of the reaction and no solvent was used; a gas and a solvent are cognitive loads to students as the one is not perceptible and the other is not involved in the reaction although it is the more abundant chemical in the system. In addition, no ions had to be considered that would be a supplementary source of difficulty (De Vos and Verdonk, 1985). Another advantage of the esterification reaction was that among the two products of the reaction, one was well known (water) and the other was not (ester). The fact that one product was known and not the other could be one of the variables of our research.

This research uses the two-world model to reveal students' descriptions of the chemical reaction concept. This explanatory framework (i.e., the two-world model) can be very useful in helping chemistry teachers and instructors identify and understand their students' conceptions of chemical concepts and phenomena.

### Theoretical Framework

In chemistry, a modeling activity is usually involved when a person makes an interpretation, an explanation or a prediction relative to the chemical system that he/she observes in an experimental situation (Le Maréchal, 1999). It is important in modeling activities to categorize students' knowledge on appropriate levels (Tiberghien, 1994; Tiberghien and Megalakaki, 1995). As an example, Tiberghien considered an experimental level (objects-events) and a theoretical one (theories-models) in order to categorize students' physics knowledge (Sensevy, Tiberghien, Santini, Laube and Griggs, 2008; Tiberghien, Vince and Gaidioz, 2009). In chemistry, this modeling activity involves the perceptible world on the one hand and the reconstructed world on the other. Each world is structured on three levels: the level of objects, the level of events and the level of properties (El Bilani, 2007; Khanfour-Armalé, 2008; Le Maréchal, 1999; Pekdağ, 2005; Pekdağ and

Le Maréchal, 2007).

#### *Perceptible Levels*

• Perceptible objects are objects everyone can see, such as test tubes or the liquids they hold. From a cognitive point of view, a perceptible object can be considered as the relation between a signified, a signifier, and an empirical referent (Vergnaud, 1990). In the case of a test tube, the signified is the concept of the test tube, defined as a cylindrical piece of glass, closed at one end that can hold chemicals. The signifier can be the word “test tube” or a drawing of a test tube, for example. Empirical referents could be a given test tube, a bigger one, or a tiny one. For each perceptible object it is therefore possible to consider the triplet: the signified (the conceptual sense built of the object in the mind; this is relative to the semantic domain), the signifier (the representation of the object; this is relative to the semiotic domain), and the empirical referent (the object itself).

• The perceptible events level corresponds to anything that happens to perceptible objects such as: the tube was heated, the liquid was poured...

• The perceptible properties level gathers all that helps to describe whatever is observed: the color, the fact that an object is cold or hot...

Perceptible objects, events and properties are associated with observations in experimental situations or in everyday life situations.

#### *Reconstructed Levels*

The reconstructed world is structured on the same levels as the perceptible world, with a level of reconstructed objects, a level of reconstructed events and a level of reconstructed properties.

• The reconstructed object is an object that has a signifier and a signified without a concrete empirical referent (Sallaberry, 2000). A molecule is a reconstructed object. The signified can be defined as the ultimate subdivision of a substance that still represents it. A signifier can be its formula, a wave function... There is no empirical referent, as we cannot show a molecule. The substance ethanol is also a reconstructed object, as it has no empirical referent. For a sample of ethanol to be an empirical referent, it should be constituted only with ethanol molecules and it is known that in any sample, there will be impurities.

• Reconstructed events are any events that may happen to reconstructed objects. An esterification is such an event, as it involves substances which are reconstructed objects in a macroscopic point of view, and are also reconstructed objects in a microscopic point of view because they involve molecules.

• Reconstructed objects and events may have properties. The reconstructed object “molecule” has a weight; the reconstructed event “chemical reaction” can be fast or slow...

The reconstructed world is produced by the cognitive activity of chemists who describe matter and its transformations by means of a microscopic world. Reconstructed objects, events and properties are associated with interpretations, explanations or predictions of a person about what he/she observes in experimental situations.

Such a classification in perceptible and reconstructed levels is important in representing the cognitive activity of chemistry students. As a case in point, chloride ions or chlorine atoms are reconstructed objects whereas a liquid (in the test tube) is a perceptible object. A chemical reaction between ions is a reconstructed event whereas the formation of a white powder in the tube is a perceptible event. Most activity in chemistry can be interpreted as a manipulation of reconstructed objects in relation to perceptible ones. Schematically, the above-described levels can be represented as in Figure 1.

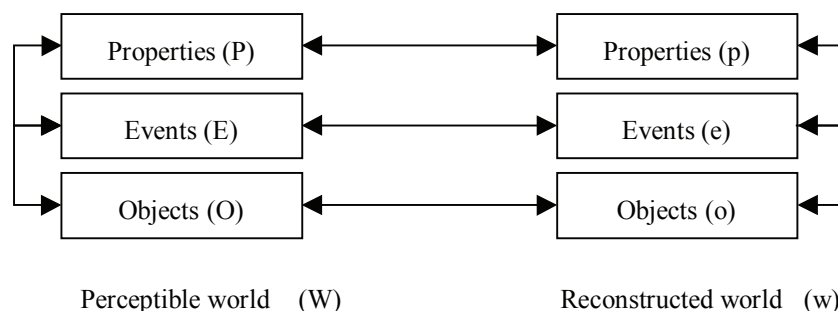

Figure 1. Schematic representation of the two-world model, and abbreviations that will be used in the following text

The arrows represent possible relations between levels of the same world or levels of both worlds. Other relations between levels are a priori possible but, at the school level of the students in the experiment, can be less often observed.

It has been shown in some cases that students frequently transpose events and properties they are familiar with in their everyday life (i.e. in the perceptible world) into the reconstructed one and vice versa. Building a symmetrical representation of the perceptible world and the reconstructed world is interesting as it offers a glimpse into which objects, events and properties students will actually transpose and into which world. As a case in point, they would declare that to prepare a sodium chloride solution, they would mix sodium ions and chloride ions in water. This example shows that sometimes students build relations on different levels of the perceptible and reconstructed worlds (Le Maréchal, 1999). The benefit and importance of this symmetrical representation is being able to note the appropriate and inappropriate relations built between the different levels by the students. Conceptual understanding in chemistry would thus include the ability to represent and translate chemical problems using perceptible and reconstructed levels.

This research deals with the description of the concept of chemical reaction by students. Differing from previous other studies on chemistry education based on this concept, the two-world model will be used here to categorize the students' descriptions.

#### *Research Questions*

We were interested in describing the arguments that students would use when faced with chemical reactions. This point seemed important enough to study as it may be a way to improve teaching situations related to chemical reactions. Teachers performing an experiment involving a chemical reaction usually consider that it is obvious to everyone that a chemical reaction is involved in the experiment. Our research indicated that this was far from being the case for the students. Moreover, if a student does think that a reaction is involved, will it be for an acceptable reason? To answer these questions, we set up an experiment that was conducted during laboratory work at school, and another one that was carried out outside of school with students watching the video of the same experiment.

#### Methodology

Choosing the esterification reaction as the basis of our research was a decision influenced both because of curriculum constraints and of research motivations. As indicated in the introduction of this article, we wanted to avoid reactions involving gases as a reagent or as a product, as well as ions and solutions (De Vos and Verdonk, 1985), as such reactions are known to have peculiarities and distracters. We also wanted to avoid reactions with observable change as this has been described as an essential criterion for recognizing a chemical reaction (Stavridou and Solomonidou, 1989).

Part of the experiment was organized during a laboratory work session and part of it with a video. We considered the video presentation of the experiment as a model of a teacher's demonstration, but in a perfectly reproducible and controlled manner. We hypothesized that one variable would be the time spent on working on the experiment and the others would be the facts that the students could observe and the perceptible objects of the experiment that the students would manipulate.

#### *Video*

We produced a 1 minute 43 seconds video involving almost the same perceptible objects as students would work with during a laboratory work session. The relevant objects, events and properties are given below with the scenario of the video.

The video shows two test tubes and two liquids said to be acid and alcohol. A couple of drops of acid were added on a white powder described as anhydrous copper sulfate. Copper sulfate did not change its color upon this addition, which is known by students as a fact since there is no water in the acid. The same was done with alcohol with the same result. Both liquids were mixed and heated up to boiling. Upon cooling, a couple of drops of the mixture were added on a new sample of anhydrous copper sulfate; it turned blue indicating that water was present in the mixture. The three results of the copper sulfate tests were presented at the same time in the final image of the video and the following question was explicitly posed: How is it possible to explain that the mixture turns blue with the copper sulfate whereas each constituent taken separately does not produce this blue color?

- This video showed:

- (1) Perceptible objects: liquids, powder.
- (2) Perceptible events: mixing, heating, copper sulfate test with and without color change.
- (3) Perceptible properties: the color of copper sulfate. The video could not "show" the characteristic odors of the chemicals for obvious reasons, nor could it show the fact that the mixture is homogeneous before heating and heterogeneous after, due to the simultaneous presence of water and organic chemicals in the same system. It was not visible enough on the screen in our working conditions; therefore it was not mentioned in the video.

- The video involved:

- (1) Reconstructed objects: alcohol, acid, water and ester substances. The ester, as a product of esterification was not mentioned.
- (2) Reconstructed events: chemical reaction of alcohol with acid and chemical reaction of water (in the mixture) with anhydrous copper sulfate.

- The video was organized in seven sequences:

- (1) The presentation of the acid and alcohol liquids in the perceptible world.
- (2) The negative copper sulfate test for the acid (perceptible world), but students knew enough chemistry to deduce that there is no water in the acid (reconstructed world).
- (3) The same with alcohol.
- (4) Mixture of the liquids (perceptible world).
- (5) Heating and cooling of the mixture. Although in this sequence a reconstructed event is involved (esterification reaction), it was not visible and the text of the video did not mention it. This sequence was therefore at perceptible levels.
- (6) The positive copper sulfate test with the mixture. From this perceptible event, students are likely to reconstruct that there is water in the mixture. The video did not explicitly mention it.
- (7) Finally, the three copper sulfate tests were presented and a question was posed. "Blue" and "Non-blue" appeared on the screen to clearly emphasize the importance of this perceptible property of the copper sulfate.

The text of the video was written at the perceptible level (except for the acid and alcohol reagents) in order to be sure that any reconstructed ideas in the students' words would be their own and not from the video.

Data collection was carried out with eight 15-year-old students from two different lower secondary schools in Lyon (France). Students worked in pairs. Each pair was isolated in a room with a computer in which the video was loaded. The only command they could use was to start or stop the video. They had a questionnaire with six questions related to the video. They were tape-recorded and their dialogues were entirely transcribed. The experiment that was carried out with the student pairs watching the video lasted for 25 - 35 minutes. In the rest of the article, the students will be called (Cy and Al), (Ch and La), (St and Je) and (Lo and So). This experiment took place at the very end of the year, all the curriculum requirements having been accomplished.

#### *Laboratory Work*

A laboratory assignment of 1 hour and 30 minutes was designed with the teachers. It was based on the official curriculum of the first year of the upper secondary school. This laboratory work was the last of a 4 weeks' teaching sequence on substances. Each week involved a 1 hour and 30 minutes laboratory session and one-hour of coursework. The first week was devoted to the introduction of substances (the title of the course was: The world is made of substances). The second was dedicated to extractions of substances (from lavender). The third dealt with the separation of substances (introduction to chromatography). The last, which we used in our experiment, was the preparation of substances; we esterified an alcohol, although students ignored organic chemistry, molecules, formulae and chemical equations.

The laboratory work was organized around the same esterification reaction as the video, but the students would be doing it by themselves. In the three classes, students worked in pairs. Each pair was given a laboratory worksheet with two kinds of information: indications to perform the experiments and questions to be answered during the experiments. This laboratory worksheet had been tested the previous year and needed only slight improvements. The role of the teacher was to introduce the laboratory work session, to technically give guidance to the students who needed it, and to conceptually help the student if necessary. On this last point, almost no support was necessary as the laboratory worksheet was prepared so that the students could be as autonomous as possible. Teachers were accustomed to this way of doing laboratory work and knew they had to minimize their interventions because the laboratory handout would be collected as research data. One of the researchers was present as a passive observer. One pair of students was video- and audio-recorded during the laboratory work session and the dialogue was transcribed.

#### *Available data for the research*

Altogether, we had written products from 42 pairs of students in three classes of the upper secondary schools (laboratory worksheets), the transcription of a pair of students in one of the three classes (laboratory work discussion), and the transcription of 4 pairs of students in the lower secondary school (discussion about the video).

#### *Analytical methodology of research data*

Our analysis was aimed at learning the concept of chemical reaction. We made an analysis of the students' output on both the laboratory worksheet and in verbal interactions. We looked for the arguments that the students would use in relation to the fact that their observations would or would not correspond to a chemical reaction. Our analysis was based on the categories described above with respect to the perceptible and reconstructed worlds.

## Results

The results associated with the video and the laboratory experiment are presented below.

### *Results associated with the video experiment*

The analysis of the transcription of 4 pairs of students who watched the video revealed that they used three kinds of arguments to convince each other about the chemical reaction. Most arguments used by students in the lower secondary school were perceptible events; these were used 12 times out of 19. On the contrary, reconstructed properties were least used by students as an argument-only 3 times out of 19.

1) Students used a perceptible event (12/19)

- 5 times about the fact that there was no change of color

Ch: few drops of the content of the left test tube [acid] were put on anhydrous copper sulfate / what did you observe? (he reads question 2a) / well, it does not change color / what can we deduce about it?

La: wait (she writes the answer) / there is no reaction

- 3 times about a change of color

St: what did you observe? (he reads question 5a)

Je: there is a color change

St: a color change (he writes the answer) / what can you deduce from it? (he reads question 5b) / well, sulfate reacts

Je: with the mixture

- 4 times about heating

Al: what do you want to do?

Cy: liquid mixing / plus heating / then there is a reaction

2) Students used a perceptible property (4/19)

- Once with the homogeneous aspect of the system

Je: that stuff is homogeneous

St: yes yes / there is no reaction

- 3 times about the blue color of copper sulfate

Al: chemical reaction / there is one / with blue

3) Students used a reconstructed property (3/19)

- Once about the fact that a chemical reaction is irreversible (which is not really true)

Cy: a chemical reaction is something irreversible

- Once about the fact that a chemical reaction must produce something

Lo: because it [the chemical reaction] gives nothing

- Once with properties of reconstructed objects

Ch: I think there is water / it's not impossible / it's the mixture for example / in alcohol there is oxygen for example / in the acid there is hydrogen / when you mix it / it makes water...

Students (15 years old) generally described the concept of chemical reaction in terms of levels of the perceptible world (16 times out of 19), as color change (E), heating (E), and change of the perceptible property of the chemical system (P). These results reveal that arguments from the perceptible world seem more convincing than arguments from the reconstructed world at this



school level. For a teacher, a chemical test (reconstructed event) is necessary to be convinced of the existence of chemical reaction whereas students will essentially look for perceptible events. Even if students have all the information needed to arrive at a correct conclusion, they may consider only the perceptible ones. In our case, the key step would necessitate focusing on the formation of water so we heard: “acid plus alcohol / it makes water / it is not possible”. “Acid and alcohol makes water” is a reconstructed event that suffices for all chemists to conclude there is a chemical reaction. For students, however, this is not a normally expected event.

#### *Results from the laboratory experiment*

The results obtained from the transcription of a pair of students and from the written output of 42 pairs of students in three classes of the upper secondary school are given below.

#### Results from the transcription

Studying the dialogue of the pair of students who were thoroughly recorded showed:

- That what happened is a change of perceptible property: “have a homogeneous substance become a heterogeneous substance”

- This change of perceptible property went with a means: “... by heating”, which is a perceptible event.

- Last, the transformation resulting from a mechanism: “the mixture becomes heterogeneous because of the water that appeared and condensed in the condenser [from the fog the student saw during the experiment]”. This mechanism is expressed in terms of perceptible events.

Therefore, although it was clear for students that during this experiment, they were conscious that water was being formed and that this water was detected by the copper sulfate test, the chemical reaction was, to them, based on purely perceptible aspects.

#### Results from the students’ written products

Only the part of the students’ written products related to our research questions are presented here. This analysis allows us to point out that students used several levels of each world and established relations between them. These relations are indicated between brackets. For example, [(O),(o)] represents a relation established by a pair of students between a perceptible object and a reconstructed object. If this relation between the two worlds involves more than two levels, it is simply noted as [(W), (w)]. Results of three questions are given in Tables 1-3. The results for the three schools are kept separated to point out the differences from school to school, although no analysis of this difference was carried out. The last question “How can you explain it?” provided information on the arguments students used.

#### Question 1. How can you be sure of it?

We asked students how they could be sure they had used acid and alcohol to perform their experiments.

Table 1.

*Frequencies for each category occurring in question 1*

	School 1 (N=18)	School 2 (N=10)	School 3 (N=14)
perceptible world (34)	9 (O), 1 (E), 5 (P)	4 (O), 3 (E), 3 (P)	6 (O), 1 (E), 2 (P)
reconstructed world (5)	2 (p)		3 (p)
relations between both worlds (10)	5 [(W),(w)]		1 [(O),(o)], 1 [(E),(e)], 3 [(W),(w)]

Table 1 shows that a large majority of answers (69%, 34/49) are in the perceptible world. 10% (5/49) are in the reconstructed world and 21% (10/49) set up a relation between both. Examples of all levels used by students are given below:

(O): "looking at boxes"

(E): "because we did the mixture ourselves"

(P): "the mixture was homogeneous"

(P): "thanks to the smell and to the appearance"

(p): "because we tested both substances did not contain water therefore they were pure"

[(O),(o)]: "to detect acid we could use litmus paper". Here, students establish a relation between a perceptible object (litmus paper) and a reconstructed object (acid).

[(E),(o)]: "to see if there is no water we tested it with anhydrous copper sulfate that gets blue with water". Students constructed a relation between a perceptible event (getting blue) and a reconstructed object (water). Here, the water is a reconstructed object because it is in a chemical product, therefore not perceptible.

[(W), (w)]: "doing the anhydrous copper sulfate test"

[(W), (w)]: "we could perform chromatography".

Both these last examples are relations between perceptible and reconstructed worlds, as the anhydrous copper sulfate test as well as chromatography involves perceptible objects, events and properties to obtain information about the reconstructed world.

Question 2. What can be said about substances in the flask once it has been heated then cooled?

Table 2.

*Frequencies for each category occurring in question 2*

	School 1 (N=18)	School 2 (N=10)	School 3 (N=14)
perceptible world (14)	3 (P)		7 (O), 4 (P)
reconstructed world (31)	15 (o)	10 (o)	3 (o), 1 (e), 2 (p)
relations between both worlds (0)			

Table 2 shows 78% (35/45) involved objects (perceptible as well as reconstructed), and no answer was related to both worlds. An example used by students: "we have the water substance (o)". Here, the water is a reconstructed object, as one knows it is water only as an interpretation of a test. It would be different in: "It is tap water".

Question 3. How can you explain it?

Table 3.

*Frequencies for each category occurring in question 3*

	School 1 (N=18)	School 2 (N=10)	School 3 (N=14)
perceptible world (15)	2 (E), 2 (P)	2 (E), 2 (P)	7 (E)
reconstructed world (27)	1 (o), 12 (e), 5 (p)	3 (p), 1 [(o),(e)]	1 (e), 4 (p)
relations between both worlds (23)	4 [(E),(e)], 1 [(P),(o)]	2 [(E),(o)], 7 [(E),(e)], 1 [(E),(p)]	5 [(E),(e)], 1 [(E),(p)], 2 [(P),(p)]

Table 3 shows 23% (15/65) of answers are in the perceptible world, 42% (27/65) are in the reconstructed world and 35% (23/65) are related to both. Examples of levels used by students are given below:

(E): "the copper sulfate changed its color"

(P): "because the smell is different"

(o): "the water is one of the products"

(e): "because there was a chemical transformation"

[(o), (e)]: "the acid reacted with the alcohol to produce a new chemical substance"

[(E), (o)]: "in my opinion, heating the flask it produced water"

[(E), (o)]: "there is an ester because we could smell it"

[(E),(e)]: "the heat produced a chemical reaction"

[(E),(p)]: "we observed that the sulfate changed its color therefore tube number one contains water"

[(P), (o)]: "the smell is not the same therefore we created a new substance"

[(P), (p)]: "the copper sulfate was blue therefore tube number one contains water"

The results of this experiment show that students do establish relations between the two worlds and most relations involve the same kind of levels: [(O),(o)], [(E),(e)] or [(P),(p)]. In the three tables above, only 18% (6/33) do not respect this rule.

### Discussion

This study aimed to determine students' verbal and written descriptions related to the chemical reaction concept on the basis of a two-world model. Altogether, the results of this study allowed a comparison of two teaching situations involving a chemical experiment, the basic characteristic of which are:

- The experiment performed by the teacher is rather short to save teaching time, aims at proposing a phenomenon to students, and is worked out during the course of the lecture.
- The laboratory experiment lasts longer (1 to 2 hours) and each student can work at his/her own pace. If the extra (compare to teacher experiment) time devoted to the laboratory work session is well organized, students will use it to build relevant knowledge.

In this research we observed that students were able to develop a larger variety of argument during the laboratory work session compared to after they had watched a video. This variety can stem from two main causes: *the time* which the student has to develop his/her argument, and *the richness of contact with the real objects of chemistry*, compared with the use of video. The perceptual side of an experimental situation of laboratory work type puts the student in front of a richer situation: the student sees and chooses better, he/she can have olfactory information. On the other hand, a video is less rich, but it has the advantage of allowing the student to return easily to certain moments of a chemical transformation about which he/she has doubt as to what he/she saw or whose aspects he/she did not remember.

During the laboratory session, the water and the ester are kept by certain students as synthesized chemical substances because the olfactory test of laboratory work suggests to them that new chemical substances are produced by the reaction. For example, students heat a chemical system and get back something which possesses a smell, and this smell is not the same as the smell of the reactives. It is the smell of a new chemical substance. This mechanism is taken as a base by certain students in upper secondary school. The olfactory modification and the notion of the new chemical substance are connected, and this link is used as an argument. Our study thus showed that during a laboratory work session, the larger variety of perceptible arguments (visual and olfactory) are effectively used by students, and contribute to the establishment of relations between perceptible and reconstructed worlds.

With the video, technical reasons obliged us to propose only one test of the occurrence of the chemical reaction (copper sulfate). This test was used as an argument by the majority of the students in the lower secondary school. On the other hand, numerous students did not succeed in associating the levels of the perceptible world (e.g. color change) with a new chemical substance (reconstructed object). After the video, students kept thinking in terms of perceptible

world. Some research has shown that students describe chemical reactions as physical changes (e.g. color change) (Hesse and Anderson, 1992; Van Driel, De Vos, Verloop and Dekkers, 1998). Students kept to perceptible arguments that are not acceptable from a chemical point of view. Learning is therefore at a lower level.

In chemistry education, previous studies have indicated that students considered surface features while classifying chemical reactions: visible elements of a given chemical representation such as the charge of a particle represented by symbols or the state of matter of a substance indicated by symbols such as s (for solid) or g (for gas). Students paid attention to the surface features (visible elements) of a chemical reaction and they failed to create chemically meaningful classes. There was unfamiliarity with the microscopic images of chemical reactions in all of the students' explanations (Stains and Talanquer, 2008). In our case we observed that the students' descriptions of the chemical reaction concept were based on two main perceptual features: smell changes and aspect changes in the chemical system (copper sulfate turning blue, homogeneous/heterogeneous). Kozma and Russell (1997) reported that for many students, an understanding of chemistry is built on the perceptual or surface features of physical signs (e.g. change in color) and symbolic expressions (e.g. color of balls in an animation, the labels on a graph). Students often use perceptual features to generate an understanding of chemistry.

Previous research suggests that students often identify heat as the causal agent of change and a substance can be transmuted into another substance by the action of an agent such as heat (Andersson, 1990). For these students heat causes a chemical reaction (Boo and Watson, 2001; Krnel, Watson and Glažar, 1998). In this study, we pointed out that heating has been said to be responsible for the perceptible modification of the chemical system. The smell changes or the aspect changes in the chemical system (homogeneous/heterogeneous, copper sulfate turning blue) are frequently considered by students as a result of the heating event. As students do not know much about the concept of chemical reaction, they first think of the perceptible changes in the chemical system. The chemical reaction for them is thus the modification of a perceptible property of the chemical system resulting from the heating. Students' understanding of the chemical reaction concept is lacking. Students need to change their conceptions regarding chemical reactions (De Vos and Verdonk, 1985; Hesse and Anderson, 1992; Stavridou and Solomonidou, 1998).

The fact that perceptible evidence is related to a chemical reaction goes without saying. On the one hand, when the teacher sees a reconstructed event such as a chemical reaction, students first see perceptible events. On the other hand, where the teacher expects specific (reconstructed) events as the proof of the existence of a reaction such as the results of chemical tests, students will think of (perceptible) events that are not acceptable, such as heating. For teachers (as for chemists), the links between perceptible and reconstructed worlds are so strongly established that it may not be possible for them to take into account that students "live" only in the perceptible one. Students cannot see the world with the same eyes as chemists.

Furthermore, conceptual learning of the chemical reaction concept is related to the content of chemistry courses. In introductory chemistry lessons, chemical reactions are always associated with observable phenomena (e.g. color change, heat effect, precipitation of solid, evolution of a gas) (Bergquist and Heikkinen, 1990; Van Driel, De Vos, Verloop and Dekkers, 1998). Students' descriptions of the chemical reaction concept in terms of perceptible levels were affected by the content of chemistry courses. In order to improve students' conceptual understanding of chemical reactions, it is therefore necessary to revise the scientific content of chemistry courses and to develop a new pedagogical approach and effective teaching methods regarding this concept (Nahum, Naaman, Hofstein and Krajcik, 2007).

An observation frequently held the attention of students at the point of suggesting to them the origin of the presence of a new chemical substance (the water). This was the observation of the formation of a liquid in the condenser. This is explained by several known results. The typicality of the water among the liquids is important: "A liquid is *a priori* water". The formation of the water would thus not take place for the students within the reactional environment, but in

the condenser. There one finds a variant of a conception proposed on the fact that the chemical reaction takes place, for example in the case of combustion, between the candle and the flame. In our case, the strange side of the formation of a new chemical species would not take place there where the reagents are, that is in the balloon, but *ex nihilo* starting from the vapors present in the condenser. This also reminds us of the various stages a child goes through in learning about evaporation (Bar and Galili, 1994).

Stavridou and Solomonidou (1989) explained that chemical changes are always seen as irreversible for students. In our work, we observed that certain students mentioned the irreversible character of a chemical reaction. This is inaccurate, but this criterion is often wrongly given by teachers to differentiate physical and chemical changes. Pfundt (1981) observed that this criteria would be implicitly used. We have good reason to think that in our case, the irreversibility criterion was a taught knowledge. Some research in chemistry education reported that in situations such as these, a substantial review of teaching strategies is needed (Canpolat, 2006; Sözbilir and Bennett, 2007). In addition, Chiu (2007) explained that instruction, textbooks and teaching materials are the main sources of student conceptions. These sources influence the conceptual learning of chemistry. Adbo and Taber (2009) reported that the teaching model of the chemical concepts commonly presented by teachers and textbook authors generates inappropriate mental models in the minds of many students. Changes in teaching approaches are therefore required to better support students in developing mental models that reflect the intended target knowledge. Moreover, efficient teaching strategies and assessment tools such as computer animations must be developed.

To help students learn chemistry concepts conceptually (for example, chemical reactions), computer animations can be used in instructional environments (Burke, Greenbowe and Windschitl, 1998; Kelly and Jones, 2007). Technological tools that make connections between perceptible and reconstructed levels serve as a vehicle for students to generate mental images/models acceptable in a chemical point of view and promote students to develop conceptual understanding of chemical concepts (Wu, Krajcik and Soloway, 2001).

### Conclusion

Many topics in chemistry do not make conceptual sense and are learned by rote. Chemistry appears to be very complex to the novice learner because there are many concepts that can be observed at the perceptible levels, but that can only be explained at the reconstructed levels. In the minds of many students, there is no connection between the perceptible and reconstructed levels. Teachers often assume that students can easily pass from one world to another. Most students think about chemistry only at the perceptible levels, but the chemistry teacher is thinking simultaneously at all levels of two worlds. Students' understanding of chemistry relies heavily on sensory information. The reconstructed levels are especially difficult for students because these levels are invisible and abstract. Learning needs to go from a perceptible level to a reconstructed one; it should allow interpretation and prediction of an observed event. Effective learning requires simultaneous use of perceptible and reconstructed levels in chemical explanations. Helping students relate the two worlds has potential for improving conceptual understanding.

We consider that one of the principal difficulties of students in chemistry is not being able to build meaningful relations between the perceptible world and the reconstructed world. Conceptual learning in chemistry necessitates constructing appropriate relations between the levels of two worlds and explaining a perceptible event in the reconstructed world. Teachers should use an instructional strategy that will include relations between two worlds. Such an instructional strategy will improve students' conceptual understanding about chemical concepts and phenomena.

Most beginners in teaching do not know how to interpret their students' answers and have little idea of what to pay attention to or look for when analyzing students' work (Talanquer, 2006).

Teachers can categorize students' chemistry knowledge in terms of perceptible and reconstructed levels. Such an analysis will make it possible to reveal the relation between taught knowledge and learned knowledge. The two-world model can represent the knowledge system of any given student. This model will help the chemistry teachers to discover how knowledge is built in their students' conceptual system, identify the students' conceptions of chemical concepts and phenomena and better understand students' learning difficulties. Moreover, the two-world model can help chemistry teachers to devise instructional strategies that promote learning and understanding in chemistry.

Using the two-world model, researchers in chemistry education can analyze students' verbal and written output relative to a chemical concept or phenomenon and thus give meaningful and adequate answers to the questions "how do students learn a chemical concept or phenomenon?" (in the perceptible world or in the reconstructed world or with relations between both) and "what kind of a change takes place in students' knowledge of chemistry during the learning process? Furthermore, the two-world model can be used for analyzing chemical knowledge presented in technological tools such as videos, animations, simulations and the multimedia. This makes it possible to categorize verbal and visual chemical knowledge of a technological tool in terms of perceptible and reconstructed levels. Such an analysis will give the teacher an idea about which technological tool to place at the service of students. It will also benefit teachers in helping them to estimate the facilitating effect of technological tools on learning and in estimating the role of these tools in bringing about conceptual change in students.

#### References

- Adbo, K. & Taber, K. S. (2009). Learners' mental models of the particle nature of matter: A study of 16-year-old Swedish science students. *International Journal of Science Education*, 31(6), 757-786.
- Agung, S. & Schwartz, M. S. (2007). Students' understanding of conservation of matter, stoichiometry and balancing equations in Indonesia. *International Journal of Science Education*, 29(13), 1679-1702.
- Andersson, B. (1986). Pupils' explanations of some aspects of chemical reactions. *Science Education*, 70(5), 549-563.
- Andersson, B. (1990). Pupils' conceptions of matter and its transformations (age 12-16). *Studies in Science Education*, 18(1), 53-85.
- Bar, V. & Galili, I. (1994). Stages of children's views about evaporation. *International Journal of Science Education*, 16(2), 157-174.
- Barker, V. & Millar, R. (1999). Students' reasoning about chemical reactions: What changes occur during a context-based post-16 chemistry course? *International Journal of Science Education*, 21(6), 645-665.
- Ben-Zvi, R., Eylon, B. & Silberstein, J. (1987). Students' visualization of a chemical reaction. *Education in Chemistry*, 24, 117-120.
- Bergquist, W. & Heikkinen, H. (1990). Student ideas regarding chemical equilibrium: What written test answers do not reveal. *Journal of Chemical Education*, 67(12), 1000-1003.
- Boo, H.-K. & Watson, J. R. (2001). Progression in high school students' (aged 16-18) conceptualizations about chemical reactions in solution. *Science Education*, 85(5), 568-585.
- Burke, K. A., Greenbowe, T. J. & Windschitl, M. A. (1998). Developing and using conceptual computer animations for chemistry instruction. *Journal of Chemical Education*, 75(12), 1658-1660.
- Cakmakci, G., Leach, J. & Donnelly, J. (2006). Students' ideas about reaction rate and its relationship with concentration or pressure. *International Journal of Science Education*, 28(15), 1795-1815.
- Canpolat, N. (2006). Turkish undergraduates' misconceptions of evaporation, evaporation rate, and vapour pressure. *International Journal of Science Education*, 28(15), 1757-1770.
- Cavallo, A., McNeely, J. C. & Marek, E. A. (2003). Eliciting students' understandings of chemical

- reactions using two forms of essay questions during a learning cycle. *International Journal of Science Education*, 25(5), 583-603.
- Chiu, M.-H. (2007). A national survey of students' conceptions of chemistry in Taiwan. *International Journal of Science Education*, 29(4), 421-452.
- Cokelez, A., Dumon, A. & Taber, K. S. (2008). Upper secondary French students, chemical transformations and the "register of models": A cross-sectional study. *International Journal of Science Education*, 30(6), 807-836.
- De Vos, W. & Verdonk, A. H. (1985). A new road to reactions. *Journal of Chemical Education*, 62(3), 238-240.
- El Bilani, R. (2007). "Nature des connaissances mises en jeu par les élèves et les enseignants lors de l'utilisation des TICE en chimie: Cas de la réaction chimique dans l'enseignement secondaire." Doctoral thesis, Université Lumière Lyon 2, Lyon.
- Gabel, D. L., Samuel, K. V. & Hunn, D. (1987). Understanding the particulate nature of matter. *Journal of Chemical Education*, 64(8), 695-697.
- Gopal, H., Kleinsmidt, J., Case, J. & Musonge, P. (2004). An investigation of tertiary students' understanding of evaporation, condensation and vapour pressure. *International Journal of Science Education*, 26(13), 1597-1620.
- Hesse, J. J. & Anderson, C. W. (1992). Students' conceptions of chemical change. *Journal of Research in Science Teaching*, 29(3), 277-299.
- Kelly, R. M. & Jones, L. L. (2007). Exploring how different features of animations of sodium chloride dissolution affect students' explanations. *Journal of Science Education and Technology*, 16(5), 413-429.
- Khanfour-Armalé, R. (2008). "Structuration par le professeur des connaissances construites par des élèves ayant travaillé en autonomie lors d'une activité expérimentale de chimie." Doctoral thesis, Université Lumière Lyon 2, Lyon.
- Kozma, R. B. & Russell, J. (1997). Multimedia and understanding: Expert and novice responses to different representations of chemical phenomena. *Journal of Research in Science Teaching*, 34(9), 949-968.
- Krnel, D., Watson, R. & Glažar, S. A. (1998). Survey of research related to the development of the concept of 'matter'. *International Journal of Science Education*, 20(3), 257-289.
- LeMaréchal, J.-F. (1999). Modelling student's cognitive activity during resolution of problems based on experimental facts in chemical education. In J. Leach & A. C. Paulsen (Eds.), *Practical work in science education – Recent research studies* (pp. 195-209). Denmark, Frederiksberg: Roskilde University Press/Holland, Dordrecht: Kluwer Academic Publishers.
- Mulford, D. R. & Robinson, W. R. (2002). An inventory for alternate conceptions among first-semester general chemistry students. *Journal of Chemical Education*, 79(6), 739-744.
- Nahum, T. L., Naaman, R. M., Hofstein, A. & Krajcik, J. (2007). Developing a new teaching approach for the chemical bonding concept aligned with current scientific and pedagogical knowledge. *Science Education*, 91(4), 579-603.
- Nakhleh, M. B. (1992). Why some students don't learn chemistry. *Journal of Chemical Education*, 69(3), 191-196.
- Novick, S. & Nussbaum, J. (1981). Pupils' understanding of the particulate nature of matter: A cross-age study. *Science Education*, 65(2), 187-196.
- Pekdağ, B. (2005). "Influence des relations entre le texte et l'image d'un film de chimie sur l'activité cognitive d'un apprenant." Doctoral thesis, Université Lumière Lyon 2, Lyon.
- Pekdağ, B. & Le Maréchal, J.-F. (2007). Memorisation of information from scientific movies. In R. Pintó & D. Couso (Eds.), *Contributions from science education research* (pp. 199-210). Netherlands, Dordrecht: Springer.
- Pfundt, H. (1981). Pre-instructional conceptions about substances and transformations of substances. In W. Jung, H. Pfundt & C. von Rhoneck (Eds.), *Proceedings of the international workshop on problems concerning students' representation of physics and chemistry knowledge* (pp. 320-341). Pedagogische Hochschule, Ludwigsburg.
- Sallaberry, J.-C. (2000). Coordination des "représentations image" et des représentations rationnelles dans la construction du concept d'élément chimique. *Didaskalia*, 17, 101-121.

- Sanger, M. J. & Greenbowe, T. J. (1997). Common student misconceptions in electrochemistry: Galvanic, electrolytic, and concentration cells. *Journal of Research in Science Teaching*, 34(4), 377-398.
- Sanmarti, N., Izquierdo, M. & Watson, R. (1995). The substantialisation of properties in pupils' thinking and in the history of science. *Science & Education*, 4(4), 349-369.
- Schmidt, H.-J. & Volke, D. (2003). Shift of meaning and students' alternative concepts. *International Journal of Science Education*, 25(11), 1409-1424.
- Sensevy, G., Tiberghien, A., Santini, J., Laube, S. & Griggs, P. (2008). An epistemological approach to modeling: Cases studies and implications for science teaching. *Science Education*, 92(3), 424-446.
- Sözbilir, M. & Bennett, J. M. (2007). A study of Turkish chemistry undergraduates' understanding of entropy. *Journal of Chemical Education*, 84(7), 1204-1208.
- Stains, M. & Talanquer, V. (2008). Classification of chemical reactions: Stages of expertise. *Journal of Research in Science Teaching*, 45(7), 771-793.
- Stavridou, H. & Solomonidou, C. (1989). Physical phenomena - chemical phenomena: Do pupils make the distinction? *International Journal of Science Education*, 11(1), 83-92.
- Stavridou, H. & Solomonidou, C. (1998). Conceptual reorganization and the construction of the chemical reaction concept during secondary education. *International Journal of Science Education*, 20(2), 205-221.
- Stefani, C. & Tsapralis, G. (2009). Students' levels of explanations, models, and misconceptions in basic quantum chemistry: A phenomenographic study. *Journal of Research in Science Teaching*, 46(5), 520-536.
- Talanquer, V. (2006). Commonsense chemistry: A model for understanding students' alternative conceptions. *Journal of Chemical Education*, 83(5), 811-816.
- Tan, K. C. D. & Taber, K. S. (2009). Ionization energy: Implications of preservice teachers' conceptions. *Journal of Chemical Education*, 86(5), 623-629.
- Tiberghien, A. (1994). Modeling as a basis for analyzing teaching-learning situations. *Learning and Instruction*, 4(1), 71-87.
- Tiberghien, A. & Megalakaki, O. (1995) Characterization of a modelling activity for a first qualitative approach to the concept of energy. *European Journal of Psychology of Education*, 10(4), 369-383.
- Tiberghien, A., Vince, J., & Gaidioz, P. (2009). Design-based research: Case of a teaching sequence on mechanics. *International Journal of Science Education*, 31(17), 2275-2314.
- Van Driel, J. H., De Vos, W., Verloop, N., & Dekkers, H. (1998). Developing secondary students' conceptions of chemical reactions: The introduction of chemical equilibrium. *International Journal of Science Education*, 20(4), 379-392.
- Vergnaud, G. (1990). La théorie des champs conceptuels. *Recherches en Didactique des Mathématiques*, 10(2), 133-170.
- Wu, H.-K., Krajcik, J. S., & Soloway, E. (2001). Promoting understanding of chemical representations: Students' use of a visualization tool in the classroom. *Journal of Research in Science Teaching*, 38(7), 821-842.